

1 2 3 4 5 6 7 8

REVISIONS		
ISS	ZONE	DESCRIPTION\PER REQUEST\DATE

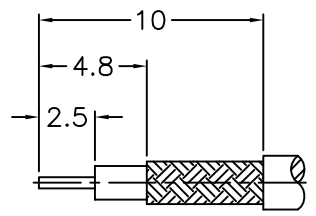

RECOMMENDED
CABLE STRIPPING DIM'S
(建議剝線尺寸)

7/16-28UNEF-2B

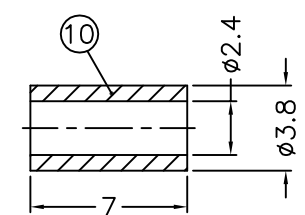
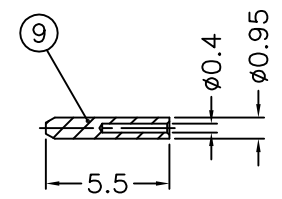
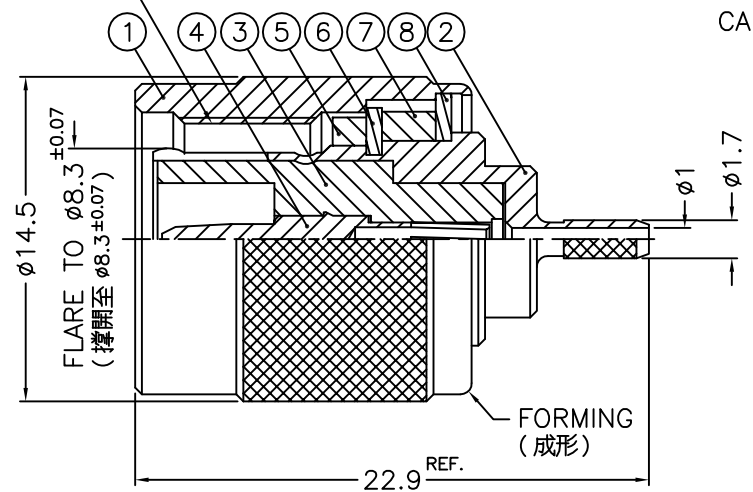

- NOTES: FINISH (PLATING THICKNESS IN MICRO-INCHES)
- BRASS
 - NICKEL PL. 100 MIN. THICK OVER COPPER PL. 50 MIN. THICK
 - GOLD PL. 3 MIN. THICK OVER NICKEL PL. 50 MIN. THICK OVER COPPER PL. 50 MIN. THICK
 - PHOSPHOR BRONZE
 - TEFLON

10	FERRULE	COPPER	NOTE 2	1	FR-24-38-70C
9	CONTACT PIN	NOTE 1	NOTE 3	1	PIN-04-095-55
8	WASHER	NOTE 1	NOTE 2	1	WS-90-128-08
7	RING	DELRIN	NATURAL	1	71628-1000-6
6	RETAINER RING	NOTE 1	NOTE 2	1	900-1000-5
5	GASKET	RUBBER	RED	1	GS-80-105-15
4	CONTACT PIN	NOTE 4	NOTE 3	1	900-1121G1-4-1.05
3	INSULATOR	NOTE 5	NATURAL	1	900-1121G1-3-50T
2	BODY	NOTE 1	NOTE 2	1	900-1121G1-2-01
1	SHELL	NOTE 1	NOTE 2	1	71628-1000-1

DIMENSIONS ARE IN MILLIMETERS
UNLESS OTHERWISE SPECIFIED TOLERANCES
0.5-6 = ±0.2
6-30 = ±0.4
30-120 = ±0.6
120-315 = ±1
315-1000 = ±1.6
1000-2000 = ±2.4

PART NO.	
APPROVED	DATE 07-07-'14
CHECKED	DATE 07-07-'14
DRAWN	DATE 07-07-'14

RoHS COMPLIANT

- CRIMPED FERRULE
HEX CRIMP SIZE .128"
- CRIMPED CONTACT PIN
SQ. CRIMP SIZE 0.7mm

TITLE	TNC CRIMP PLUG (FOR RG-178, 196 CABLE)
DRAWING NO.	71628-1121G1-01-50
FILE NO.	R:\D\G\DWG\71628\1121G1\01\50-1

NO.	DESCRIPTION	MATERIAL	FINISH	Q'TY	DRAWING NO.	SCALE	3/1	ISSUE	A
1									

1 2 3 4 5 6 7 8