

1			2			3			4			5			6			7			8		
REVISIONS																							
ISS	ZONE	DESCRIPTION\PER REQUEST\DATE																					

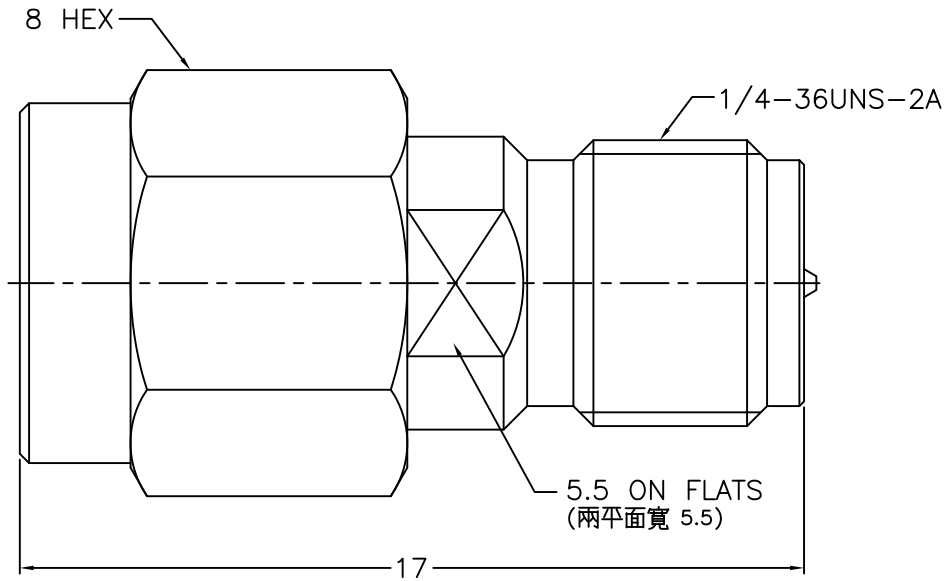

NOTES: FINISH (PLATING THICKNESS IN MICRO-INCHES)

1. BRASS
2. THIN GOLD OVER NICKEL PL. 50 MIN. THICK OVER COPPER PL. 50 MIN. THICK
3. GOLD PL. 3 MIN. THICK OVER NICKEL PL. 50 MIN. THICK OVER COPPER PL. 50 MIN. THICK
4. TEFLON

						DIMENSIONS ARE IN MILLIMETERS				PART NO.									
6	CONTACT PIN	NOTE 1	NOTE 3	1	100-SMAM-RSMAM-6	UNLESS OTHERWISE SPECIFIED TOLERANCES 0.5-6 = ±0.2 6-30 = ±0.4 30-120 = ±0.6 120-315 = ±1 315-1000 = ±1.6 1000-2000 = ±2.4				APPROVED		DATE		TITLE SMA PLUG TO SMA REVERSE POLARITY JACK ADAPTOR					
5	GASKET	SILICONE	RED	1	GS-43-60-06							06-05-'13							
4	RETAINER RING	SUS303	NATURAL	1	1436-1000-4														
3	INSULATOR	NOTE 4	NATURAL	2	1436-5071A1-3T							CHECKED		DATE		DRAWING NO.			
2	BODY	NOTE 1	NOTE 2	1	1436-5071A1-2									06-05-'13		100-SMAM-RSMAM-50			
1	SHELL	NOTE 1	NOTE 2	1	1436-1000-1							DRAWN		DATE		FILE NO. R:\D\G\DWG\100\SMAM-RSMAM\50			
NO.	DESCRIPTION	MATERIAL	FINISH	Q'TY	DRAWING NO.	SCALE	6/1	ISSUE	A	06-05-'13									

1			2			3			4			5			6			7			8		
---	--	--	---	--	--	---	--	--	---	--	--	---	--	--	---	--	--	---	--	--	---	--	--