

N3100BA-0142	N Plug Crimp	50Ω
--------------	--------------	-----

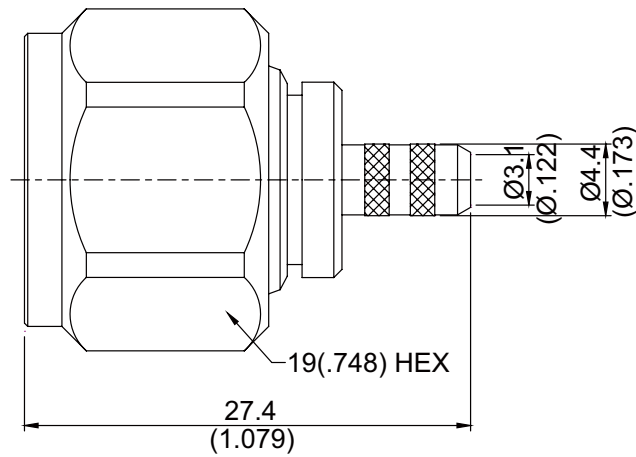

Parts	Material	Plating (Micro-inch)
Ferrule	Copper	Tin-Zinc-Copper-Alloy 100 Over Copper 50
Gasket	Silicon	
Contact Pin	Brass	Gold 4 Over Nickel Phosphorous Alloy 80 Over Copper 20
Insulator	Teflon	
Body	Brass	Tin-Zinc-Copper-Alloy 100 Over Copper 50
Coupling Nut	Brass	Tin-Zinc-Copper-Alloy 100 Over Copper 50

Weight:
Suitable Cables:RG55, RG142, RG142-LSFH, RG400, RG400-LSFH

This part number complies with RoHS.

Notice: JYEBAO reserves the right to make modifications deemed appropriate.

JYE BAO CO., LTD.

CABLE ASSEMBLY INSTRUCTION

N3100BA-0142	DATE	2018/02/13	REV	A
A	B	C		
BODY	CONTACT PIN	FERRULE		
DIAGRAM	ASSEMBLY INSTRUCTION			
	Step 1: STRIP AS SHOWN.			
	<p>Step 2: SLIDE FERRULE " C " OVER CABLE.</p> <p>Step 3: PUT 0.4 MM GAGE IN PLACE, INSERT CABLE'S CENTER CONDUCTOR INTO CENTER PIN " B " AND SOLDER OR CRIMP IN " Y ". (USE SQUARE 1.6mm/0.063inch SECTION OF INSERT-B IF CRIMPED)</p>			
	Step 4: LOOSEN BRAIDING AND SLIDE CONNECTOR " A " IN PLACE.			
	<p>Step 5: SLIDE FERRULE " C " TOWARDS THE CONNECTOR " A " AND CRIMP. (USE 5.5mm/0.217inch HEX SECTION OF INSERT-B)</p>			

This part number complies with RoHS.

Notice: JYEBAO reserves the right to make modifications deemed appropriate.

APPROVED

CHECKED

DRAWING