

BNC 75 Ohm, jack to jack, bulkhead

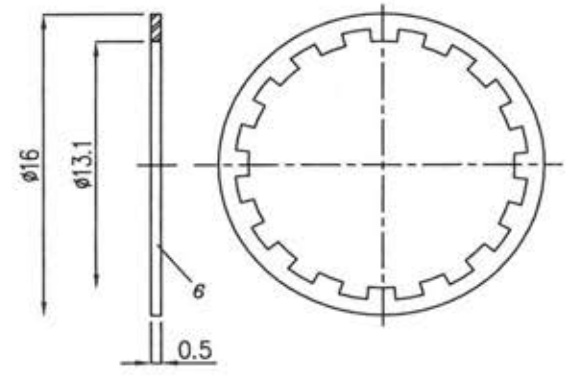
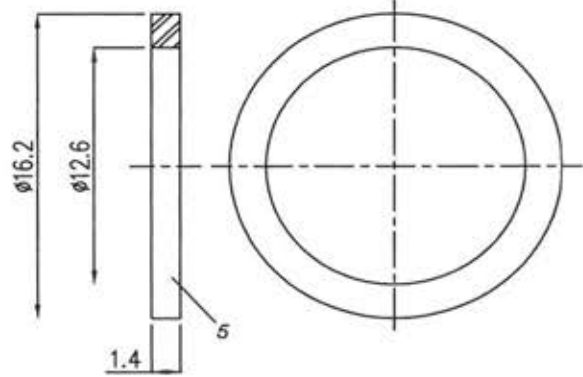
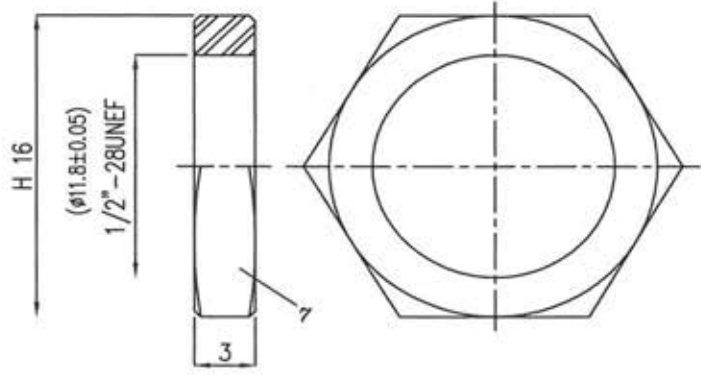
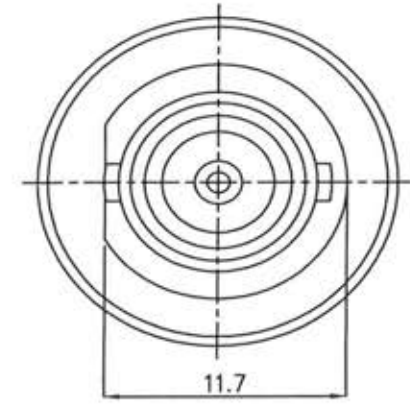
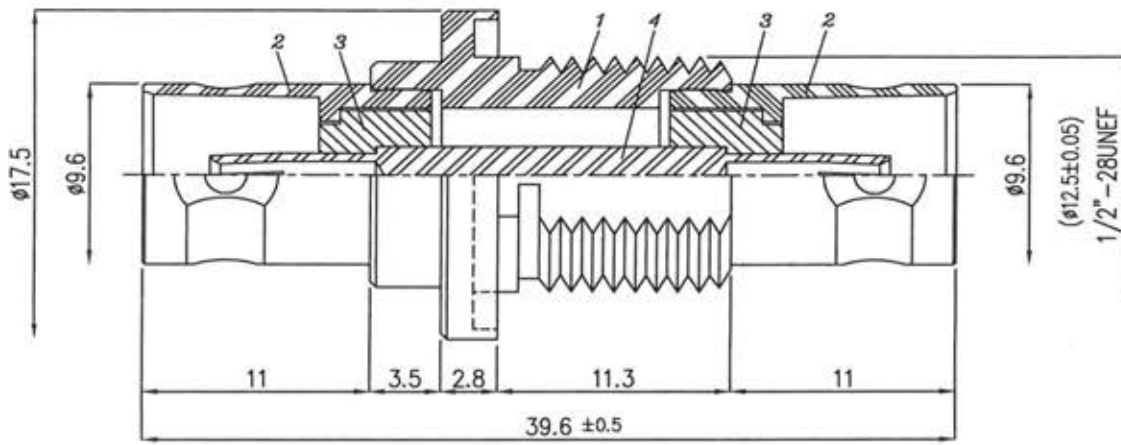

Unit: mm

General tolerances:

0-0.5mm ± 0.10mm	0.5-8mm ± 0.20mm
8-30mm ± 0.40mm	30-120mm ± 0.50mm

NO	DESCRIPTION	Q'TY	MATERIAL	PLATING
1	BODY 1	1	BRASS	NICKEL 100 μ" MIN.
2	BODY 2	2	BRASS	NICKEL 100 μ" MIN.
3	DIELECTRIC	2	PTFE	-
4	CENTER PIN	1	BRASS	GOLD 3-5 μ" MIN.
5	WATERPROOF SEAL	1	RUBBER	-
6	LOCK WASHER	1	BRASS	NICKEL 100 μ" MIN.
7	NUT	1	BRASS	NICKEL 100 μ" MIN.

All material in accordance with RoHS + REACH!

Prep.:	Date:	Rev.:	Date:	Remark:	Prep.:	Check.:	Item No.:
J.A.	21.05.15						73271-75
Check.:	Date:						
Approv.:							

EAN Bar Code:	
All rights reserved	Page 1 of 1