

Bulkhead BNC jack 75 Ohm

crimp type for cable-Ø 6,00 - 6,15 mm (RG62A/U 93Ω, RG59B/U)

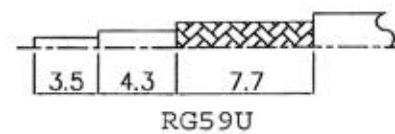
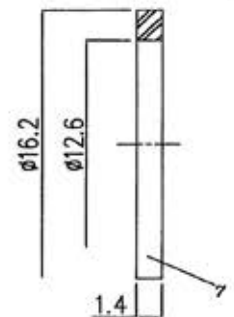
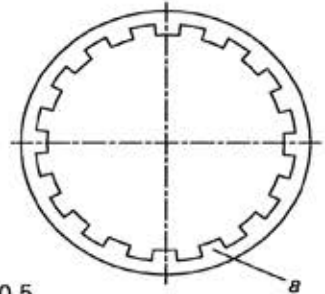
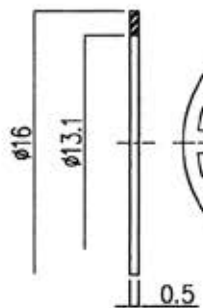
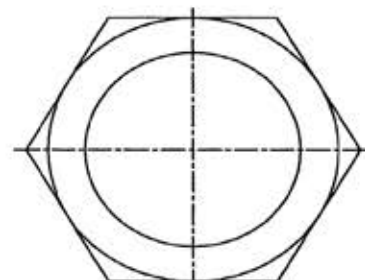
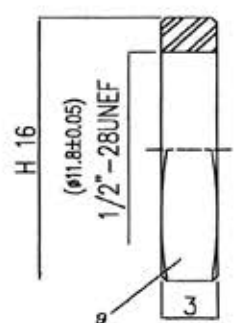
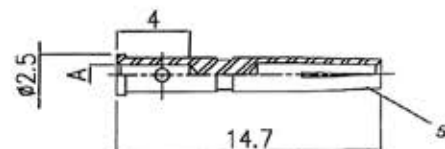
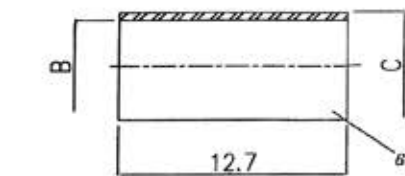
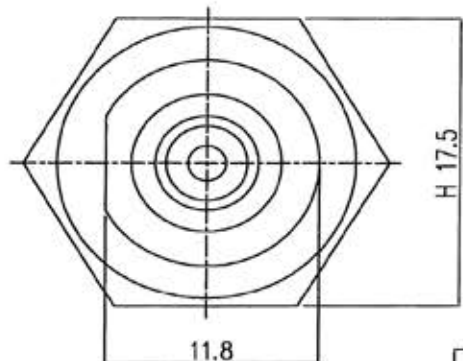
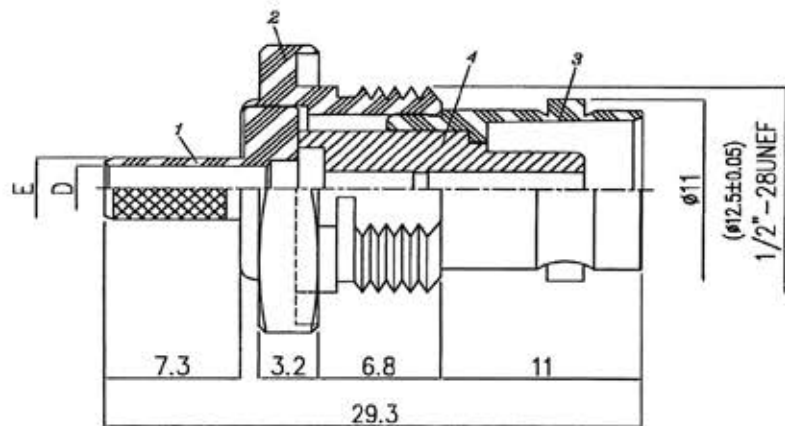

A	B	C	D	E
0.75	6.6	7.5	4.1	5.5

Unit in mm

Tolerances:

0-0.5mm ± 0.10mm	0.5-8mm ± 0.20mm
8-30mm ± 0.40mm	30-120mm ± 0.50mm

NO	DESCRIPTION	Q'TY	MATERIAL	PLATING
1	BODY 1	1	BRASS	NICKEL 100 μ" MIN.
2	BODY 2	1	BRASS	NICKEL 100 μ" MIN.
3	BODY 3	1	BRASS	NICKEL 100 μ" MIN.
4	DIELECTRIC	1	POM	-
5	CENTER PIN	1	BRASS	GOLD 3-5 μ" MIN.
6	FERRULE	1	BRASS	NICKEL 100 μ" MIN.
7	WATERPROOF SEAL	1	RUBBER	-
8	LOCK WASHER	1	BRASS	NICKEL 100 μ" MIN.
9	NUT	1	BRASS	NICKEL 100 μ" MIN.

All material in accordance with RoHS + REACH!

Prep.:	Date:	Rev.:	Date:	Remark:	Prep.:	Check.:
J.A.	19.05.15					
Check.:	Date:					
Approv.:						

Item No.:	
Customer Item No.:	
EAN Bar Code:	
All rights reserved	Page 1 of 1